

Production Line

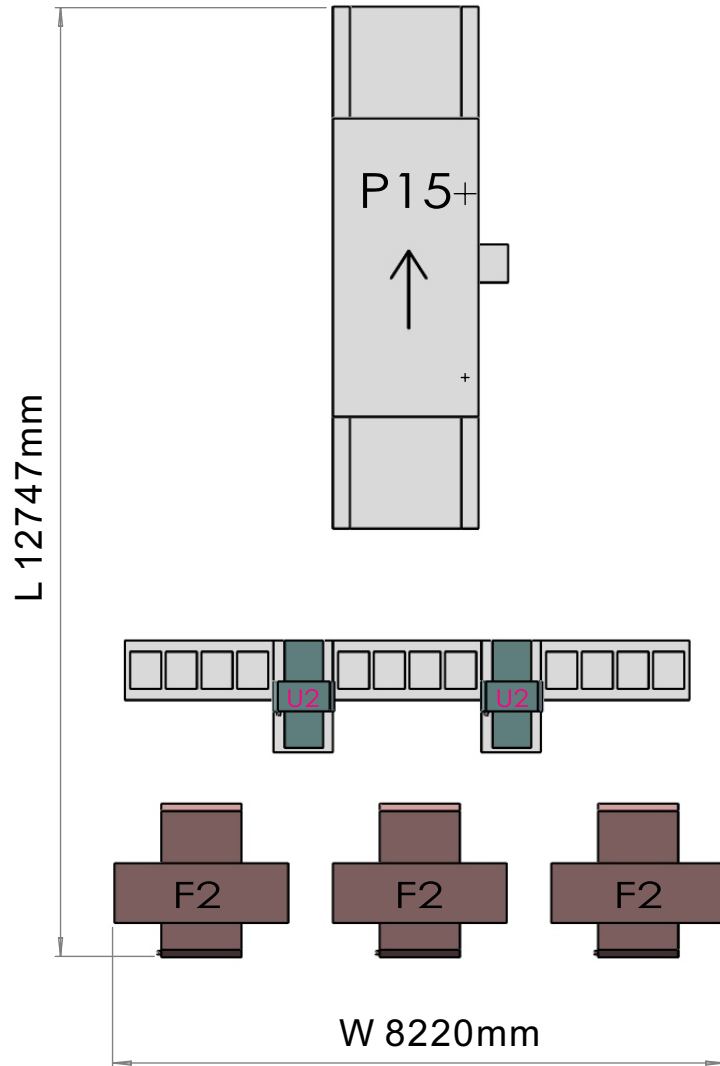

Scheme 3:
3xF2 Printers
2xU2 Pre-treatment Machines
1xP15 Tunnel Dryer

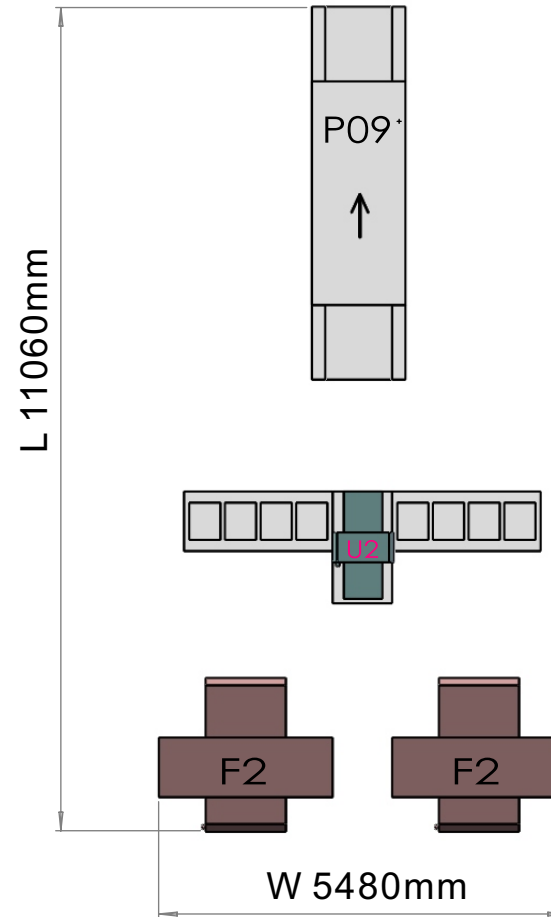

Scheme 2:
2xF2 Printers
1xU2 Pre-treatment Machine
1xP9 Tunnel Dryer

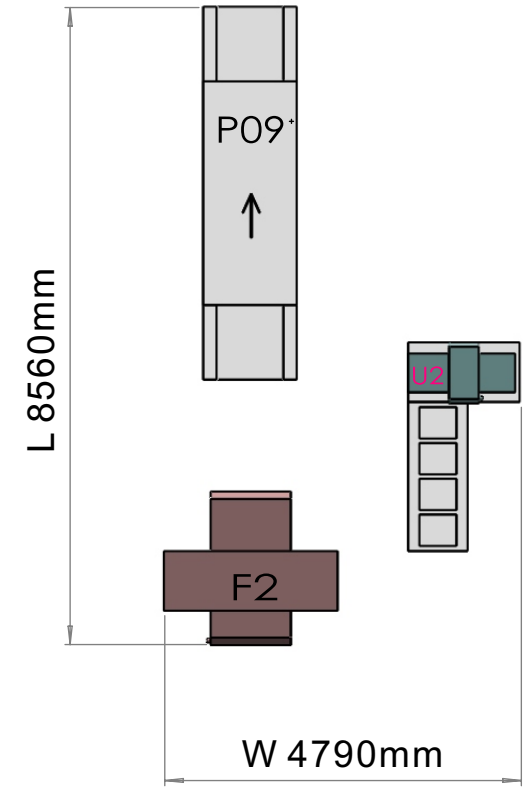

Scheme 1:
1xF2 Printer
1xU2 Pre-treatment Machine
1xP9 Tunnel Dryer

Pre-treatment Machine U2

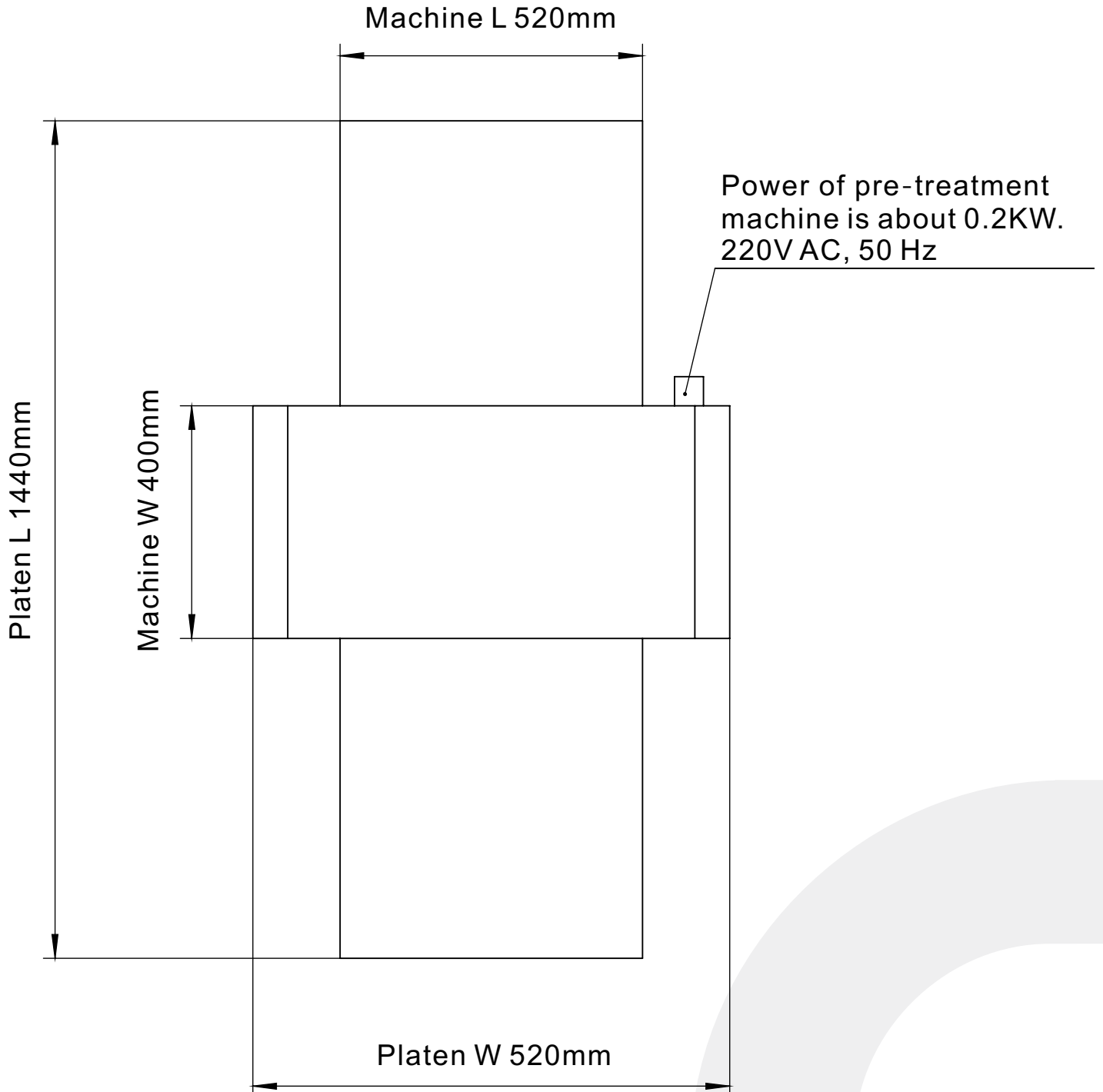

DTG Printer F2

Power of F2 is about 3KW
220V AC, 50 Hz

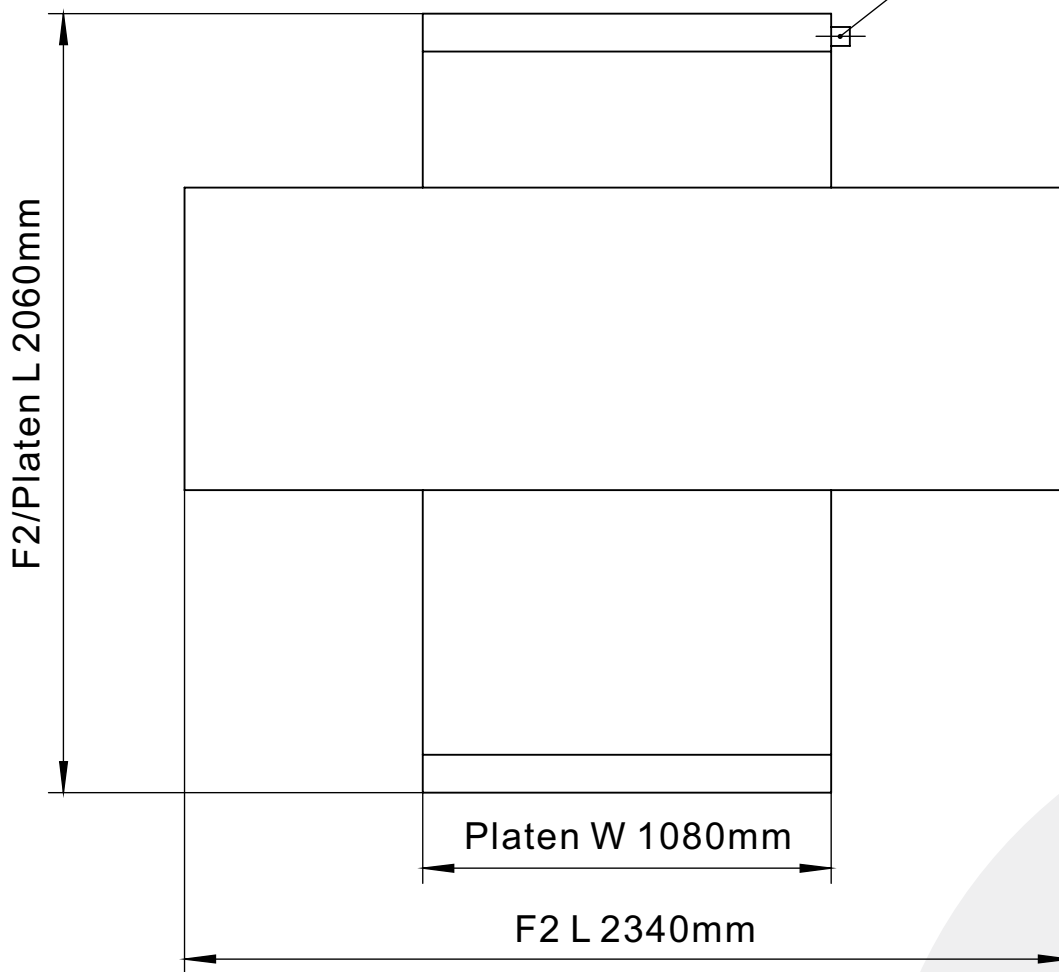

DTG Printer F3

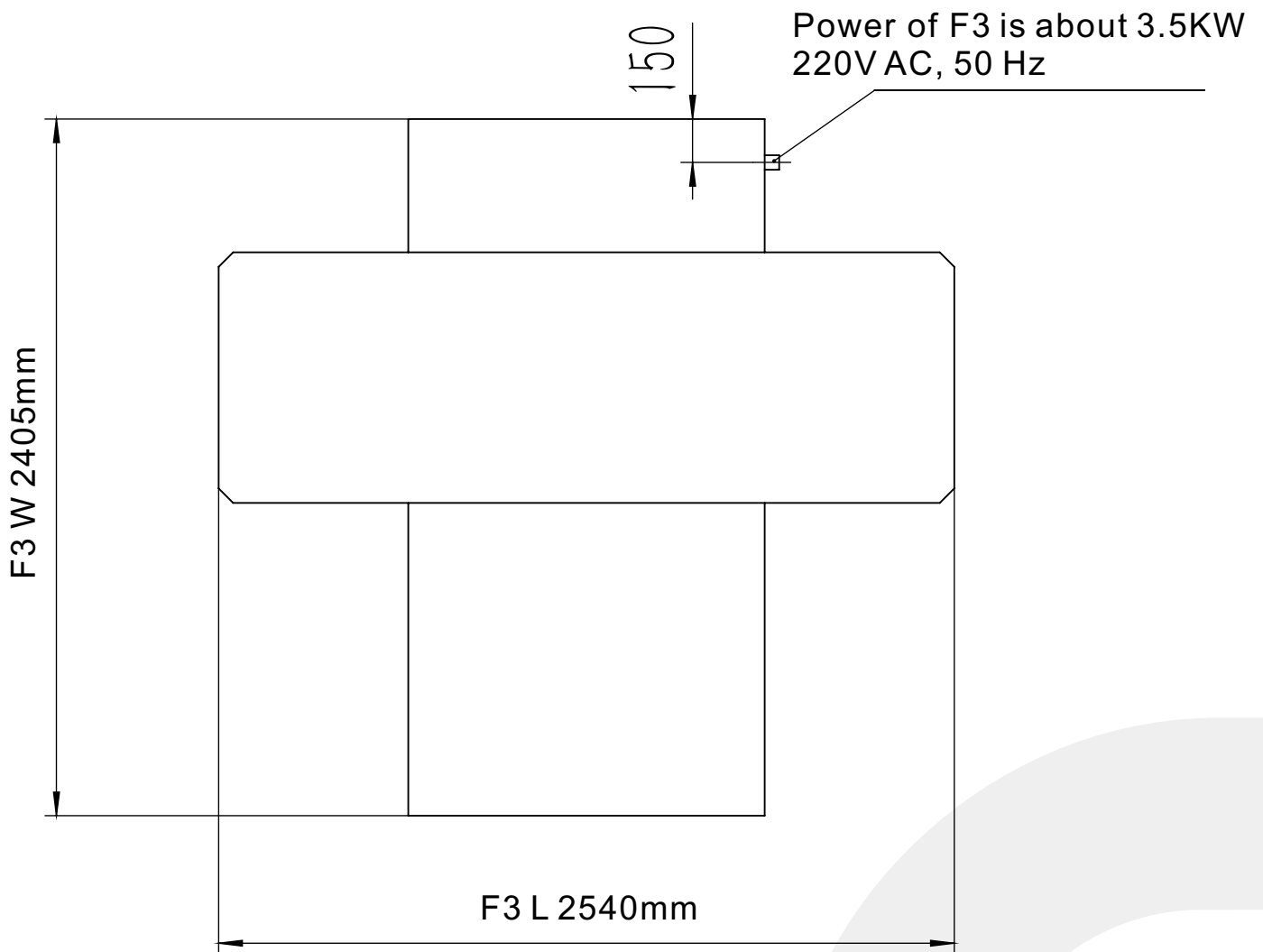

Tunnel Dryer P09

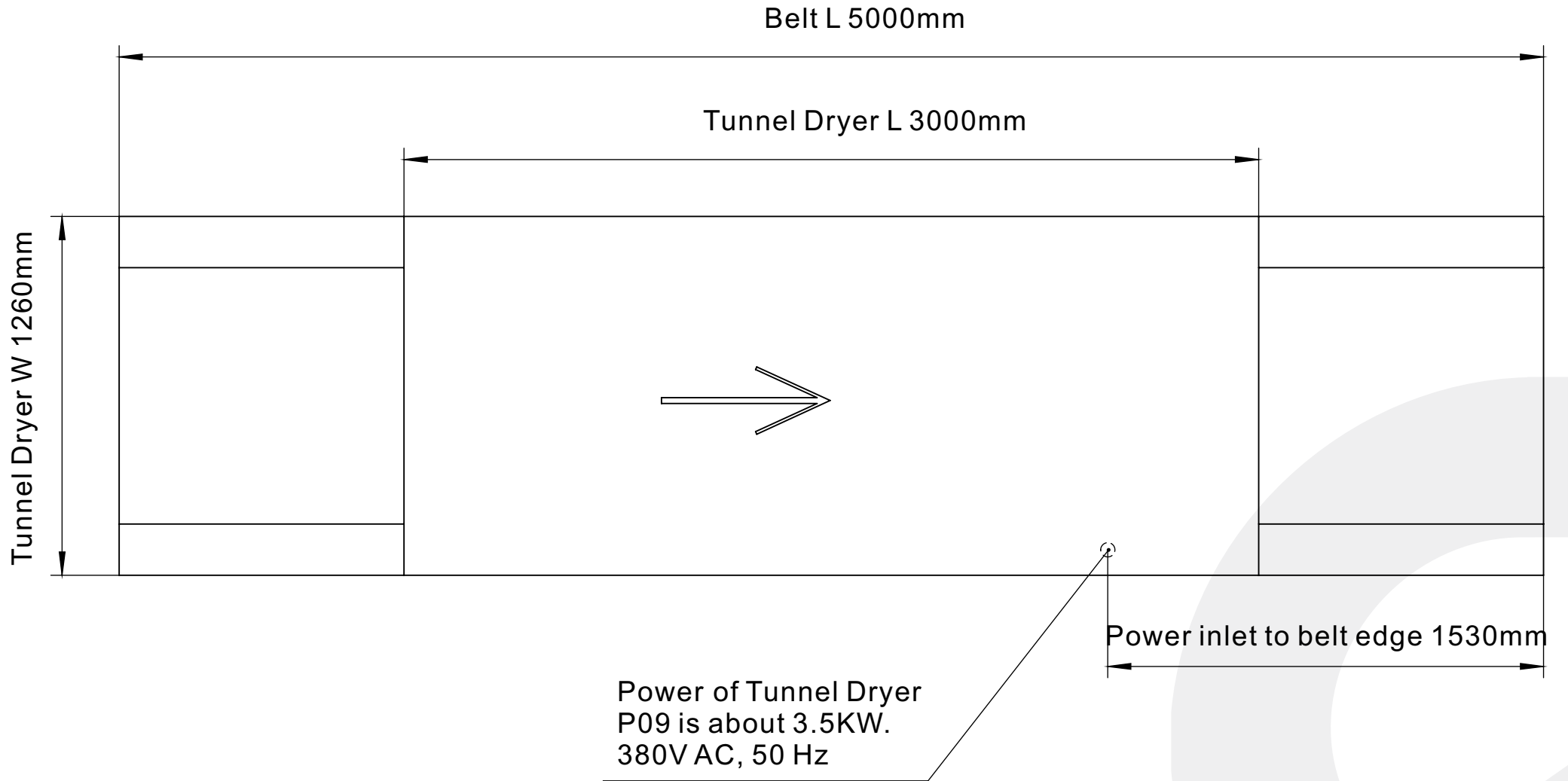

Tunnel Dryer P15

Natural gas pressure for
Tunnel Dryer P15-T is 2.5Kpa
Inlet type: G3/4.
Power is about 3KW.
380V AC 50Hz

Power of Tunnel Dryer
P15-Q is about 45KW
380V AC 50Hz

Power inlet to belt edge 2030mm

